

53K

Premium Mill Rotary Seals

High Performance Seals for Bearing and Gearbox Protection

Chesterton® 53K seals are high-performance radial seals for heavy duty, dynamic rotary seal applications. These seals provide long-lasting sealing and protective solutions that withstand high speed and large misalignment of shafts and rolls in heavy industry.

The 53K represents advanced technology: combined finger and garter springs in combination with high performance elastomers, which outlast the conventional radial oil seals in the most difficult applications.





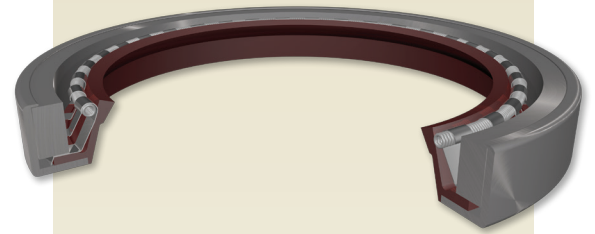

The outer metal case of 53K is cold pressed. The elastomer part is manufactured by compression molding technology that is vulcanized to the metal case, which provides very tight dimensional, geometrical tolerances. The unique design with a flat outer metal case ensures improved fitting in the seal cavity and an improved centric position. Additionally, this design allows installation in stuffing boxes without end covers.

According to industrial standards sizing, the 53K is a direct retrofit, which eliminates the need of equipment modification. The 53K is offered in different designs based on application requirements.



- Unique lip preload system with highly flexible garter-finger spring combination
- Large shaft run-out compensation capability
- Unique lip design combined with autolubricated elastomer offer low friction and ultra high surface speed
- Direct retrofit eliminates equipment modification
- High-performance elastomers ensure plant-wide usage and long service life

AVAILABLE DESIGNS

Series	Usage
53K 	with standard style with garter-finger spring system
53KW 	with additional dust lip
53KHP 	with special, robust lip profile to withstand high-pressures up to 0,1 MPa (1 bar)
53KL 	with special, optimized lip interference for high- speed applications
53KLHS 	with special, low lip interference for ultra high speed applications
53KLPT 	with integrated (vulcanized) PTFE-lip tip

Typical Applications

- High speed gear drives
- High speed back-up rolls in cold mills
- High speed back-up rolls in cold mills
- Work rolls in hot and cold mills
- Aluminum foil mills
- Paper machines
- Cement plants
- Power plants

Seal Construction

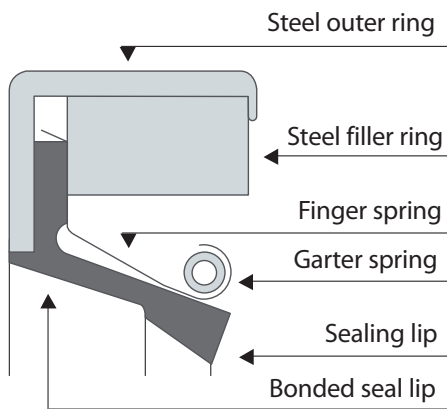

- The service life and performance of the are largely dependent upon the preload of the seal lip on the shaft. In this respect the 53K design offers a significant advantage over conventional garter spring seal types as a result of its highly elastic garter-finger spring combination.
- Shaft misalignment (shaft deflection, bearing clearance, out of round and run-out) creates changes to the lip preload that can in conventional seals compromise either or both lip tip sealing integrity and seal life.
- The finger-garter spring combination in 53K largely eliminates the effect of external forces causing changes in lip tip preload and therefore is more likely to maintain the fluid film underneath the lip the condition of which has the greatest effect on seal service life and performance.

SHAFT AND HOUSING TOLERANCES

Shaft Ø (mm)	Housing bore Ø (mm)
<= 100 +/- 0,08 (<= 4 +/-0.00315)	<= 76 +/- 0,025 (2,99 +/-0.001)
101 to 150 +/- 0,1 (4,01 to 5.9 +/- 0.004)	77 to 150 +/- 0,04 (3 to 5.9 +/-0.0016)
151 to 250 +/- 0,13 (5,91 to 9,842 +/-0.005)	151 to 255 +/- 0,05 (5.91 to 10 +/-0.002)
>= 250 +/- 0,25 (9,85 +/-0.01)	256 to 510 + 0,05/-0,10 (10.1 to 20 +0.002/-0.004)
	511 to 1.015 + 0,05/-0,15 (20,1 to 40 +0.002/0.006)
	>1.015 +0,05/-0,25 (40,1 +0.002/-0.01)

SHAFT HARDNESS AND SURFACE FINISH TOLERANCES

Speed (m/sec)	Max roughness		Hardness (HRC)
	Ra (µm)	Rmax (µm)	
<= 10 (1968)	0.5 - 0.6 (20-24)	2 - 3 (80-120)	30
11 to 16 (2165 to 3150)	0.3 - 0.5 (12-20)	1 - 2 (40-80)	40
>16 (3150)	0.2 - 0.3 (8-12)	0.8 - 1 (32-40)	50

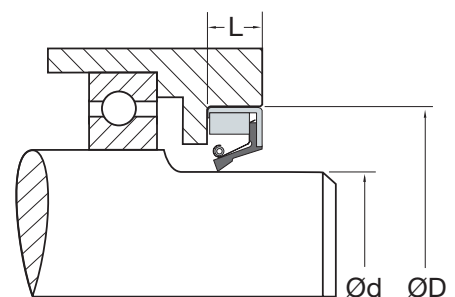

SPECIFICATIONS

Elastomers	NBR80+PTFE	FKM70+PTFE
Material of metal case	Fe-PO3	Fe-PO3
Material of steel filler ring	Fe37	Fe37
Material of spring carrier	AISI 301	AISI 301
Materials of garter spring	AISI 316	AISI 316
Lubricating greases	-20°C to 100°C (-4°F to 212°F)	20°C to 200°C (-4°F to 392°F)
Mineral oils	-20°C to 100°C (-4°F to 212°F)	-20°C to 200°C (-4°F to 392°F)
Surface speed m/s (ft/min)	25 (4921)	25 to 35 (4921 to 6889)
Technical pressure MPa (psi) 53K, 53KW, 53KL, 53KHS 53KLPT	0.05 (7.25)	0.05 (7.25)
Technical pressure MPa (psi) 53KHP	0.1 (14.5)	0.1 (14.5)
Size range mm (inch)** Seal OD	300 to 1200 (12 to 47)	300 to 1200 (12 to 47)

**Please contact your Chesterton representative for other sizes.

Chesterton ISO certificates available on www.chesterton.com/corporate/iso

Technical data reflects results of laboratory tests and is intended to indicate general characteristics only. A.W. Chesterton Company disclaims all warranties express or implied, including warranties of merchantability and fitness for a particular purpose. Liability, if any, is limited to product replacement only. Any images contained herein are for general illustrative or aesthetic purposes only and are not intended to convey any instructional, safety, handling or usage information or advice respecting any product or equipment. Please refer to relevant Safety Data Sheets, Product Data Sheets, and/or Product Labels for safe use, storage, handling, and disposal of products, or consult with your local Chesterton sales representative.

© 2017 A.W. Chesterton Company.
 ® Registered trademark owned by A.W. Chesterton Company in USA and other countries, unless otherwise noted.

Distributed by:



Area Tecnica Srl
 Strada Banchette 3/1 - 10090 Rosta (TO)
 Tel. (+39) 011 4035367 - Fax (+39) 011 4113564
info@areatecnica.it - www.areatecnica.it